



QUICK SCREEN USA.

QUICKSCREEN ALUMINUM FENCING AND GATE SYSTEMS
SPECIFICATION SHEET - COMBO SERIES

Material Specifications

Aluminum 6005/15 Structural grade alloy

Universal post-2 9/16" x 2 9/16" (8 gauge)

Slot - 2 9/16" x 5/8" (16 gauge)

Slot - 6" x 5/8" (14 gauge)

All Aluminum is manufactured to US and AUS standards including:

- USA
- ASTM B221 – Aluminum and Aluminum-Alloy Extruded Bars, Rods, Wire, Profiles, and Tubes
- ASTM B557 – Tension Testing of Aluminum Products
- ANSI H35.2-2017 - Tolerances aluminum extrusions
- AUS
- AS/NZS 1866 – Aluminium and aluminium alloys – Extruded rod, bar, solid and hollow shapes
- AS/NZS 1664 – Aluminium structures
- AS 2848.1 – Aluminium and aluminium alloys – Compositions and designation

Coating and Finishes:

- AMMA 2604 - Finishing standard Inc
- ASTM B117 – Salt Spray (Corrosion) Testing
- ASTM D3359 – Adhesion of Coatings
- ASTM D1730 – Preparation of Aluminum Surfaces for Paints/Coatings
- ASTM D4214 - Chalking Resistance.

Construction and Building applications.

- AAMA 2604
- ASCE SEI 7-10 - Minimum design loads for buildings and other structures
- AS2159 - Soil properties for footing depths
- AS1530 - Non combustible testing in accordance with ISO 1182.2010
- Australia/NZ – AS/NZS 1530.3 D2525

72" wide x 71" high Quickscreen slot panel 3/8" spacing

- 2 x Universal posts (incl caps) [95" L]
- 8 x 6" x 5/8" slots [71" L]
- 7 x 2 9/16" x 5/8" slots [71" L]
- 30 x 3/8" snap in spacers

72" wide x 71" high Quickscreen slot panel 1/2" spacing

- 2 x Universal posts Incl caps [95" L]
- 8 x 6" x 5/8" slots [71" L]
- 6 x 2 9/16" x 5/8" slots [71" L]
- 28 x 1/2" snap in spacers

72" wide x 71" high Quickscreen slot panel 1" spacing

- 2 x Universal posts (incl caps) [95" L]
- 7 x 6" x 5/8" slots [71" L]
- 6 x 2 9/16" x 5/8" slots [71" L]
- 26 x 1" snap in spacers

96" wide x 71" high Quickscreen slot panel 3/8" spacing

- 2 x Universal posts (incl caps) [95" L]
- 8 x 6" x 5/8" slots [95" L]
- 7 x 2 9/16" x 5/8" slots [95" L]
- 30 x 3/8" snap in spacers

96" wide x 71" high Quickscreen slot panel 1/2" spacing

- 2 x Universal posts Incl caps [95" L]
- 8 x 6" x 5/8" slots [95" L]
- 6 x 2 9/16" x 5/8" slots [95" L]
- 28 x 1/2" snap in spacers

96" wide x 71" high Quickscreen slot panel 1" spacing

- 2 x Universal posts (incl caps) [95" L]
- 7 x 6" x 5/8" slots [95" L]
- 6 x 2 9/16" x 5/8" slots [95" L]
- 26 x 1" snap in spacers

Single Gate (42 wide) 3/8" Spacing

- 2 x gate frames Inc screw cover [72" L]
- 1 x Gate frame kit (4 caps and screws)
- SS304 screws HD 12G Qty
- 4x 6" x 5/8" slots [cut into 2] [71" L]
- 4 x 2 9/16" x 5/8" [cut into 2] slots [71" L]
- 30 x 3/8" snap in spacers

Single Gate (42 wide) 1/2" Spacing

- 2 x gate frames Inc screw cover [72" L]
- 1 x Gate frame kit (4 caps and screws)
- SS304 screws HD 12G Qty
- 4x 6" x 5/8" slots [cut into 2] [71" L]
- 3 x 2 9/16" x 5/8" [cut into 2] slots [71" L]
- 28x 1/2" snap in spacers

Single Gate (42 wide) 1" Spacing

- 2 x gate frames Inc screw cover [72" L]
- 1 x Gate frame kit (4 caps and screws)
- SS304 screws HD 12G Qty
- 4x 6" x 5/8" slots [cut into 2] [71" L]
- 3 x 2 9/16" x 5/8" [cut into 2] slots [71" L]
- 26 x 1" snap in spacers

Double gate (192" wide)

- 4 x gate frames Inc screw cover [72" L]
- 2 x Gate frame kit (4 caps and screws)
- SS304 screws HD 12G Qty
- 16 x 6" x 5/8" slots [95" L]
- 14 x 2 9/16" x 5/8" slots [95" L]
- 60 x 3/8" snap in spacers

Double gate (192" wide)

- 4 x gate frames Inc screw cover [72" L]
- 2 x Gate frame kit (4 caps and screws)
- SS304 screws HD 12G Qty
- 16 x 6" x 5/8" slots [95" L]
- 12 x 2 9/16" x 5/8" slots [95" L]
- 56 x 1/2" snap in spacers

Double gate (192" wide)

- 4 x gate frames Inc screw cover [72" L]
- 2 x Gate frame kit (4 caps and screws)
- SS304 screws HD 12G Qty
- 14 x 6" x 5/8" slots [95" L]
- 12 x 2 9/16" x 5/8" slots [95" L]
- 52 x 1" snap in spacers

UNIVERSAL POST INSTALL METHOD

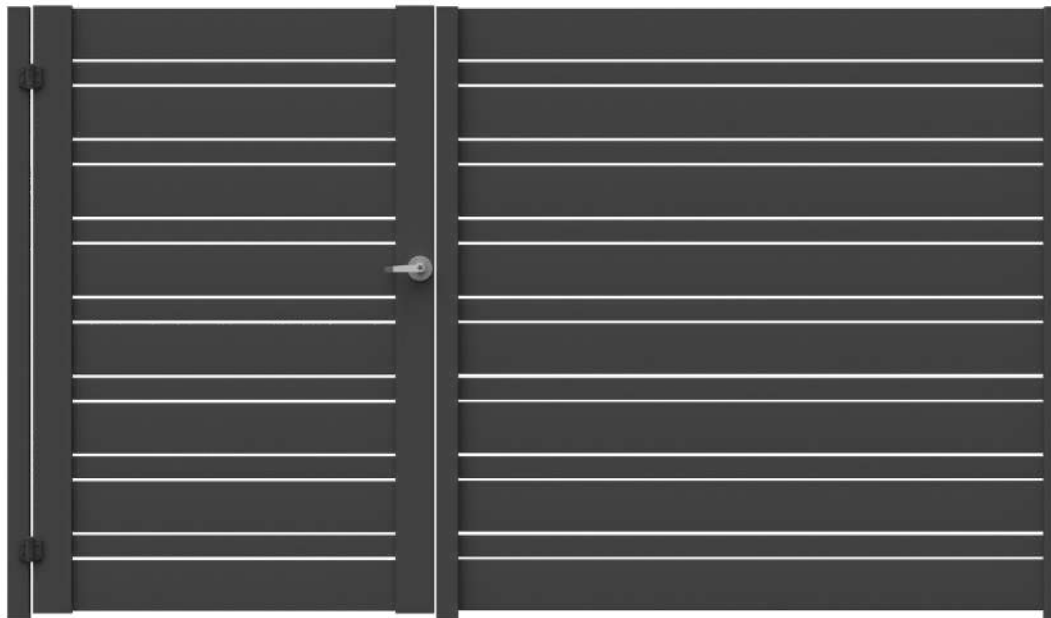

Universal Post

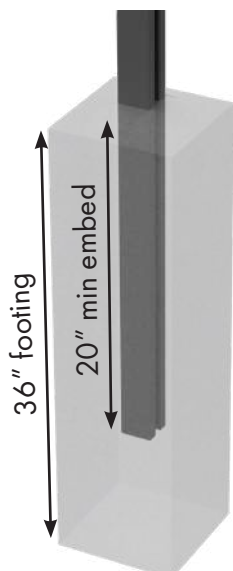

Slot

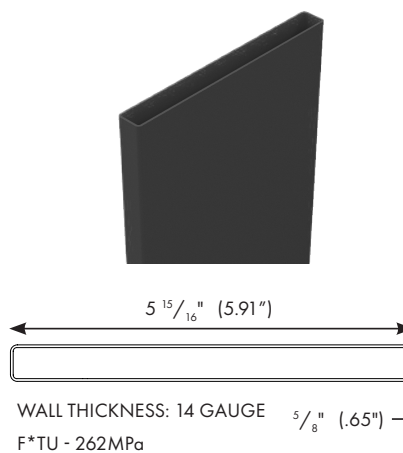
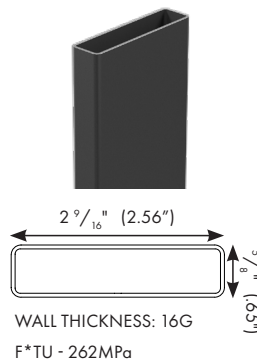

Slat Clip



Spacer blocks



3/8" SPACERS



1/2" SPACERS



1" SPACERS

Material Specifications

Aluminum 6005/15 Structural grade alloy

Universal post-2 9/16" x 2 9/16" (8 gauge)

Slot - 2 9/16" x 5/8" (16 gauge)
Slot - 6" x 5/8" (14 gauge)

All Aluminum is manufactured to US and AUS standards including:

- USA
 - ASTM B221 – Aluminum and Aluminum-Alloy Extruded Bars, Rods, Wire, Profiles, and Tubes
 - ASTM B557 – Tension Testing of Aluminum Products
 - ANSI H35.2-2017 - Tolerances aluminum extrusions
- AUS
 - AS/NZS 1866 – Aluminium and aluminium alloys – Extruded rod, bar, solid and hollow shapes
 - AS/NZS 1664 – Aluminium structures
 - AS 2848.1 – Aluminium and aluminium alloys – Compositions and designation

Coating and Finishes:

- AMMA 2604 - Finishing standard Inc
- ASTM B117 – Salt Spray (Corrosion) Testing
- ASTM D3359 – Adhesion of Coatings
- ASTM D1730 – Preparation of Aluminum Surfaces for Paints/Coatings
- ASTM D4214 - Chalking Resistance.

Construction and Building applications.

- AAMA 2604
- ASCE SEI 7-10 - Minimum design loads for buildings and other structures
- AS2159 - Soil properties for footing depths
- AS1530 - Non combustible testing in accordance with ISO 1182.2010
- Australia/NZ – AS/NZS 1530.3 D2525

72" wide x 71" high Quickscreen slot panel 3/8" spacing

- 2 x Universal posts (incl caps) (95" L)
- 8 x 6" x 5/8" slots (71" L)
- 7 x 2 9/16" x 5/8" slots (71" L)
- 30 x 3/8" snap in spacers

72" wide x 71" high Quickscreen slot panel 1/2" spacing

- 2 x Universal posts (incl caps) (95" L)
- 8 x 6" x 5/8" slots (71" L)
- 6 x 2 9/16" x 5/8" slots (71" L)
- 28 x 1/2" snap in spacers

72" wide x 71" high Quickscreen slot panel 1" spacing

- 2 x Universal posts (incl caps) (95" L)
- 7 x 6" x 5/8" slots (71" L)
- 6 x 2 9/16" x 5/8" slots (71" L)
- 26 x 1" snap in spacers

96" wide x 71" high Quickscreen slot panel 3/8" spacing

- 2 x Universal posts (incl caps) (95" L)
- 8 x 6" x 5/8" slots (95" L)
- 7 x 2 9/16" x 5/8" slots (95" L)
- 30 x 3/8" snap in spacers

96" wide x 71" high Quickscreen slot panel 1/2" spacing

- 2 x Universal posts (incl caps) (95" L)
- 8 x 6" x 5/8" slots (95" L)
- 6 x 2 9/16" x 5/8" slots (95" L)
- 28 x 1/2" snap in spacers

96" wide x 71" high Quickscreen slot panel 1" spacing

- 2 x Universal posts (incl caps) (95" L)
- 7 x 6" x 5/8" slots (95" L)
- 6 x 2 9/16" x 5/8" slots (95" L)
- 26 x 1" snap in spacers

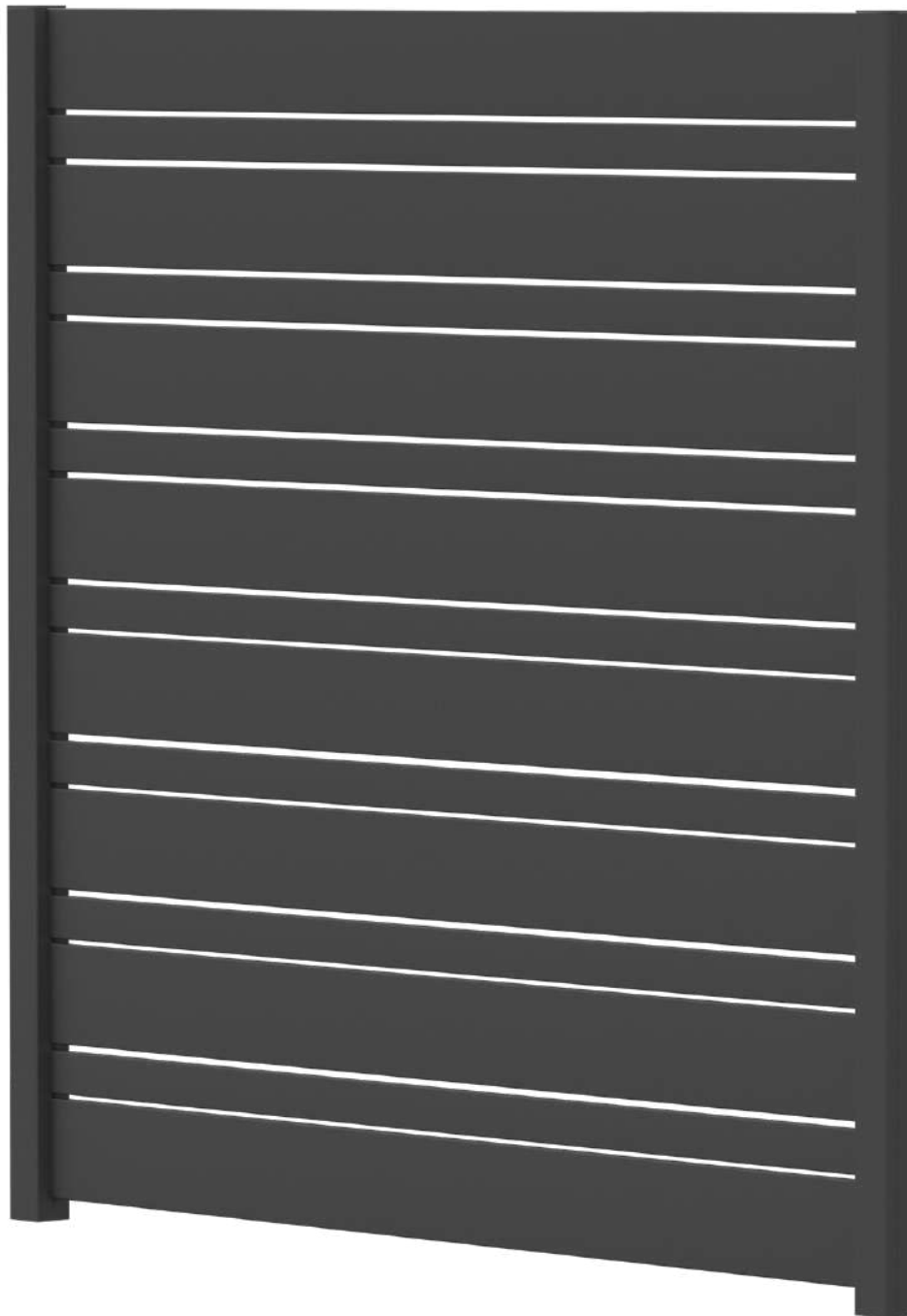

Powder coat colors —



Material Specifications

Aluminum 6005/15 Structural grade alloy

Universal post-2 9/16" x 2 9/16" (8 gauge)

Slot - 2 9/16" x 5/8" (16 gauge)

Slot - 6" x 5/8" (14 gauge)

All Aluminum is manufactured to US and AUS standards including:

- USA
 - ASTM B221 – Aluminum and Aluminum-Alloy Extruded Bars, Rods, Wire, Profiles, and Tubes
 - ASTM B557 – Tension Testing of Aluminum Products
 - ANSI H35.2-2017 - Tolerances aluminum extrusions
- AUS
 - AS/NZS 1866 – Aluminium and aluminium alloys – Extruded rod, bar, solid and hollow shapes
 - AS/NZS 1664 – Aluminium structures
 - AS 2848.1 – Aluminium and aluminium alloys – Compositions and designation

Coating and Finishes:

- AMMA 2604 - Finishing standard Inc
- ASTM B117 – Salt Spray (Corrosion) Testing
- ASTM D3359 – Adhesion of Coatings
- ASTM D1730 – Preparation of Aluminum Surfaces for Paints/Coatings
- ASTM D4214 - Chalking Resistance.

Construction and Building applications.

- AAMA 2604
- ASCE SEI 7-10 - Minimum design loads for buildings and other structures
- AS2159 - Soil properties for footing depths
- AS1530 - Non combustible testing in accordance with ISO 1182.2010
- Australia/NZ – AS/NZS 1530.3 D2525

72" wide x 71" high Quickscreen slot panel 3/8" spacing

- 2 x Universal posts (incl caps) (95" L)
- 8 x 6" x 5/8" slats (71" L)
- 7 x 2 9/16" x 5/8" slats (71" L)
- 30 x 3/8" snap in spacers

72" wide x 71" high Quickscreen slot panel 1/2" spacing

- 2 x Universal posts (incl caps) (95" L)
- 8 x 6" x 5/8" slats (71" L)
- 6 x 2 9/16" x 5/8" slats (71" L)
- 28 x 1/2" snap in spacers

72" wide x 71" high Quickscreen slot panel 1" spacing

- 2 x Universal posts (incl caps) (95" L)
- 7 x 6" x 5/8" slats (71" L)
- 6 x 2 9/16" x 5/8" slats (71" L)
- 26 x 1" snap in spacers

96" wide x 71" high Quickscreen slot panel 3/8" spacing

- 2 x Universal posts (incl caps) (95" L)
- 8 x 6" x 5/8" slats (95" L)
- 7 x 2 9/16" x 5/8" slats (95" L)
- 30 x 3/8" snap in spacers

96" wide x 71" high Quickscreen slot panel 1/2" spacing

- 2 x Universal posts (incl caps) (95" L)
- 8 x 6" x 5/8" slats (95" L)
- 6 x 2 9/16" x 5/8" slats (95" L)
- 28 x 1/2" snap in spacers

96" wide x 71" high Quickscreen slot panel 1" spacing

- 2 x Universal posts (incl caps) (95" L)
- 7 x 6" x 5/8" slats (95" L)
- 6 x 2 9/16" x 5/8" slats (95" L)
- 26 x 1" snap in spacers

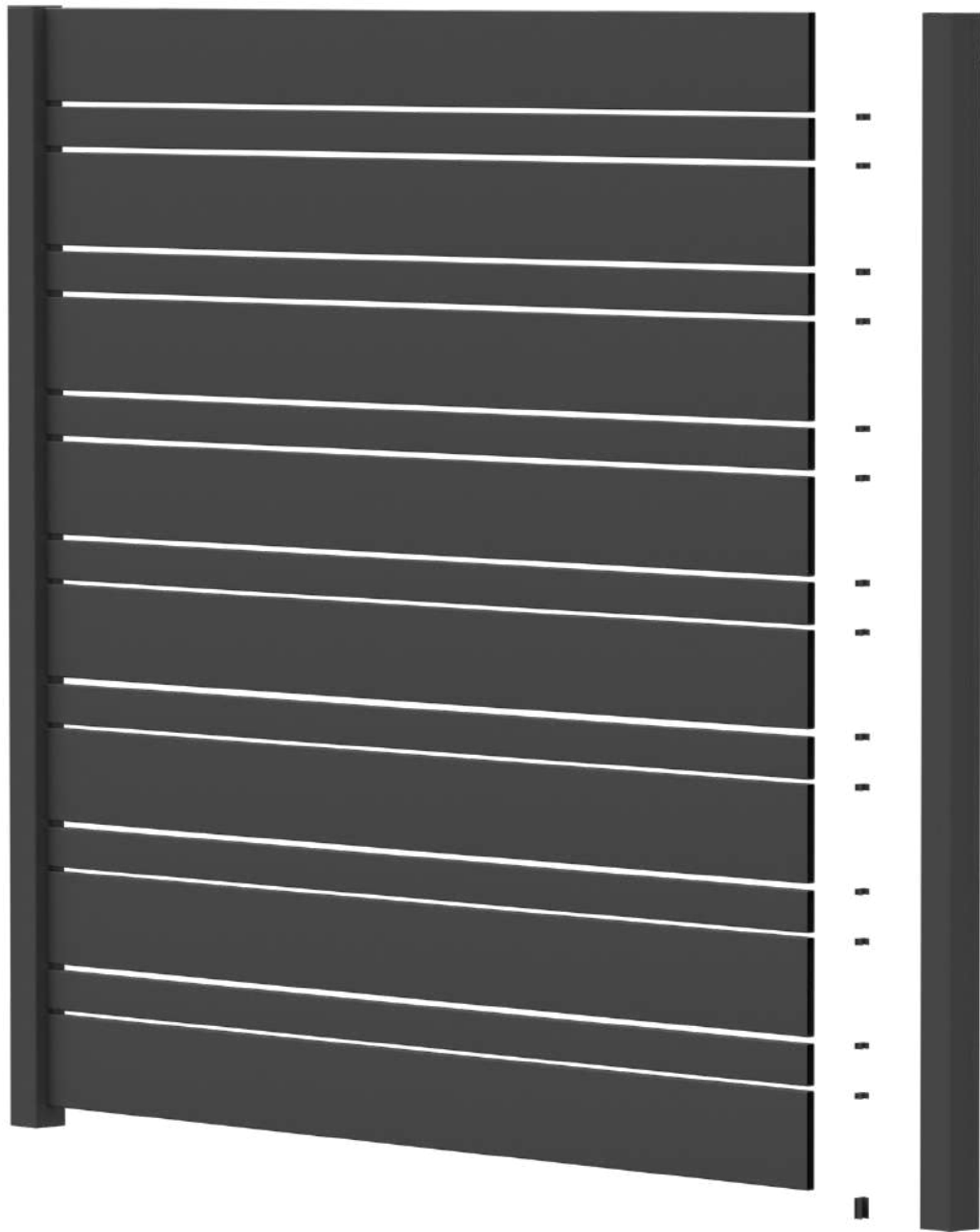

Powder coat colors —



Material Specifications

Aluminum 6005/T5 Structural grade alloy

Universal post-2 9/16" x 2 9/16" (8 gauge)

Slat - 2 9/16" x 5/8" (16 gauge)
Slat - 6" x 5/8" (14 gauge)

All Aluminum is manufactured to US and AUS standards including:

- USA
- ASTM B221 - Aluminum and Aluminum-Alloy Extruded Bars, Rods, Wire, Profiles, and Tubes
- ASTM B557 - Tension Testing of Aluminum Products
- ANSI H35.2:2017 - Tolerances aluminum extrusions
- AUS
- AS/NZS 1866 - Aluminum and aluminium alloys - Extruded rod, bar, solid and hollow shapes
- AS/NZS 1664 - Aluminium structures
- AS 2848.1 - Aluminium and aluminium alloys - Compositions and designation

Coating and Finishes:

- AMMA 2604 - Finishing standard Inc
- ASTM B117 - Salt Spray (Corrosion) Testing
- ASTM D3359 - Adhesion of Coatings
- ASTM D1730 - Preparation of Aluminum Surfaces for Paints/Coatings
- ASTM D4214 - Chalking Resistance.

Construction and Building applications.

- AAMA 2604
- ASCE SEI 7-10 - Minimum design loads for buildings and other structures
- AS2159 - Soil properties for footing depths
- AS1530 - Non combustible testing in accordance with ISO 1182:2010
- Australia/NZ - AS/NZS 1530.3 D2525

72" wide x 71" high Quickscreen slot panel 3/8" spacing

- 2 x Blank Post - 2 9/16" x 2 9/16" [incl caps] (95° I)
- OR Blank Post - 4" x 4" [incl caps] (95° I)
- 2 x Side Frame with Friction Insert and Top & Bottom Plates
- 8 x 6" x 5/8" slats (71" I)
- 7 x 2 9/16" x 5/8" slats (71" I)
- 30 x 3/8" snap in spacers

72" wide x 71" high Quickscreen slot panel 1/2" spacing

- 2 x Blank Post - 2 9/16" x 2 9/16" [incl caps] (95° I)
- OR Blank Post - 4" x 4" [incl caps] (95° I)
- 2 x Side Frame with Friction Insert and Top & Bottom Plates
- 8 x 6" x 5/8" slats (71" I)
- 6 x 2 9/16" x 5/8" slats (71" I)
- 28 x 1/2" snap in spacers

72" wide x 71" high Quickscreen slot panel 1" spacing

- 2 x Blank Post - 2 9/16" x 2 9/16" [incl caps] (95° I)
- OR Blank Post - 4" x 4" [incl caps] (95° I)
- 2 x Side Frame with Friction Insert and Top & Bottom Plates
- 7 x 6" x 5/8" slats (71" I)
- 6 x 2 9/16" x 5/8" slats (71" I)
- 26 x 1" snap in spacers

96" wide x 71" high Quickscreen slot panel 3/8" spacing

- 2 x Blank Post - 2 9/16" x 2 9/16" [incl caps] (95° I)
- OR Blank Post - 4" x 4" [incl caps] (95° I)
- 2 x Side Frame with Friction Insert and Top & Bottom Plates
- 8 x 6" x 5/8" slats (95" I)
- 7 x 2 9/16" x 5/8" slats (95" I)
- 30 x 3/8" snap in spacers

96" wide x 71" high Quickscreen slot panel 1/2" spacing

- 2 x Blank Post - 2 9/16" x 2 9/16" [incl caps] (95° I)
- OR Blank Post - 4" x 4" [incl caps] (95° I)
- 2 x Side Frame with Friction Insert and Top & Bottom Plates
- 8 x 6" x 5/8" slats (95" I)
- 6 x 2 9/16" x 5/8" slats (95" I)
- 28 x 1/2" snap in spacers

96" wide x 71" high Quickscreen slot panel 1" spacing

- 2 x Blank Post - 2 9/16" x 2 9/16" [incl caps] (95° I)
- OR Blank Post - 4" x 4" [incl caps] (95° I)
- 2 x Side Frame with Friction Insert and Top & Bottom Plates
- 7 x 6" x 5/8" slats (95" I)
- 6 x 2 9/16" x 5/8" slats (95" I)
- 26 x 1" snap in spacers

BLANK POST WITH SIDE FRAME INSTALL METHOD



4" x 4" Post OR 2 9/16" x 2 9/16" Post

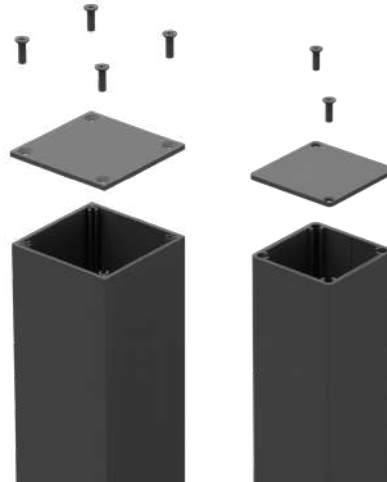

Slat

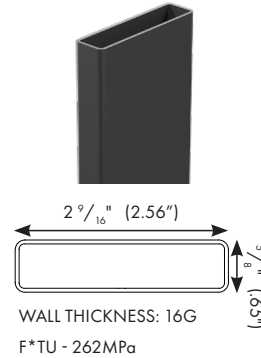

Side Frame



Spacer blocks

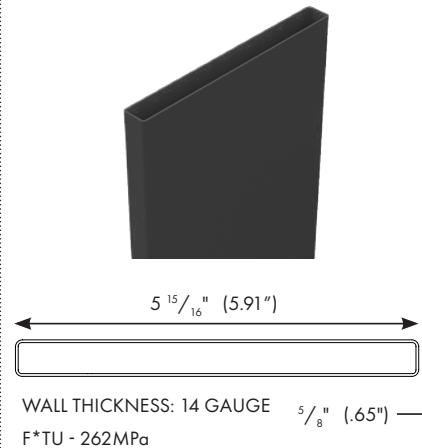
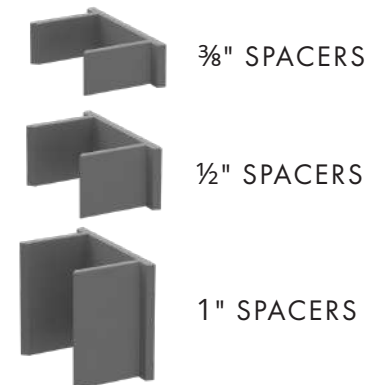

Powder coat colors —



Material Specifications

Aluminum 6005/T5 Structural grade alloy

Universal post-2 9/16" x 2 9/16" (8 gauge)

Slat - 2 9/16" x 5/8" (16 gauge)

Slat - 6" x 5/8" (14 gauge)

All Aluminum is manufactured to US and AUS standards including:

- USA
 - ASTM B221 – Aluminum and Aluminum-Alloy Extruded Bars, Rods, Wire, Profiles, and Tubes
 - ASTM B557 – Tension Testing of Aluminum Products
 - ANSI H35.2:2017 - Tolerances aluminum extrusions
- AUS
 - AS/NZS 1866 – Aluminum and aluminium alloys – Extruded rod, bar, solid and hollow shapes
 - AS/NZS 1664 – Aluminium structures
 - AS 2848.1 – Aluminium and aluminium alloys – Compositions and designation

Coating and Finishes:

- AMMA 2604 - Finishing standard Inc
- ASTM B117 – Salt Spray (Corrosion) Testing
- ASTM D3359 – Adhesion of Coatings
- ASTM D1730 – Preparation of Aluminum Surfaces for Paints/Coatings
- ASTM D4214 - Chalking Resistance.

Construction and Building applications.

- AAMA 2604
- ASCE SEI 7-10 - Minimum design loads for buildings and other structures
- AS2159 - Soil properties for footing depths
- AS1530 - Non combustible testing in accordance with ISO 1182:2010
- Australia/NZ – AS/NZS 1530.3 D2525

72" wide x 71" high Quickscreen slat panel 3/8" spacing

- 2 x Blank Post - 2 9/16" x 2 9/16" [incl caps] (95" l)
- OR Blank Post - 4" x 4" [incl caps] (95" l)
- 2 x Side Frame with Friction Insert and Top & Bottom Plates
- 8 x 6"x 5/8" slats (71" l)
- 7 x 2 9/16"x 5/8" slats (71" l)
- 30 x 3/8" snap in spacers

72" wide x 71" high Quickscreen slat panel 1/2" spacing

- 2 x Blank Post - 2 9/16" x 2 9/16" [incl caps] (95" l)
- OR Blank Post - 4" x 4" [incl caps] (95" l)
- 2 x Side Frame with Friction Insert and Top & Bottom Plates
- 8 x 6"x 5/8" slats (71" l)
- 6 x 2 9/16"x 5/8" slats (71" l)
- 28 x 1/2" snap in spacers

72" wide x 71" high Quickscreen slat panel 1" spacing

- 2 x Blank Post - 2 9/16" x 2 9/16" [incl caps] (95" l)
- OR Blank Post - 4" x 4" [incl caps] (95" l)
- 2 x Side Frame with Friction Insert and Top & Bottom Plates
- 7 x 6"x 5/8" slats (71" l)
- 6 x 2 9/16"x 5/8" slats (71" l)
- 26 x 1" snap in spacers

96" wide x 71" high Quickscreen slat panel 3/8" spacing

- 2 x Blank Post - 2 9/16" x 2 9/16" [incl caps] (95" l)
- OR Blank Post - 4" x 4" [incl caps] (95" l)
- 2 x Side Frame with Friction Insert and Top & Bottom Plates
- 8 x 6"x 5/8" slats (95" l)
- 7 x 2 9/16"x 5/8" slats (95" l)
- 30 x 3/8" snap in spacers

96" wide x 71" high Quickscreen slat panel 1/2" spacing

- 2 x Blank Post - 2 9/16" x 2 9/16" [incl caps] (95" l)
- OR Blank Post - 4" x 4" [incl caps] (95" l)
- 2 x Side Frame with Friction Insert and Top & Bottom Plates
- 8 x 6"x 5/8" slats (95" l)
- 6 x 2 9/16"x 5/8" slats (95" l)
- 28 x 1/2" snap in spacers

96" wide x 71" high Quickscreen slat panel 1" spacing

- 2 x Blank Post - 2 9/16" x 2 9/16" [incl caps] (95" l)
- OR Blank Post - 4" x 4" [incl caps] (95" l)
- 2 x Side Frame with Friction Insert and Top & Bottom Plates
- 7 x 6"x 5/8" slats (95" l)
- 6 x 2 9/16"x 5/8" slats (95" l)
- 26 x 1" snap in spacers

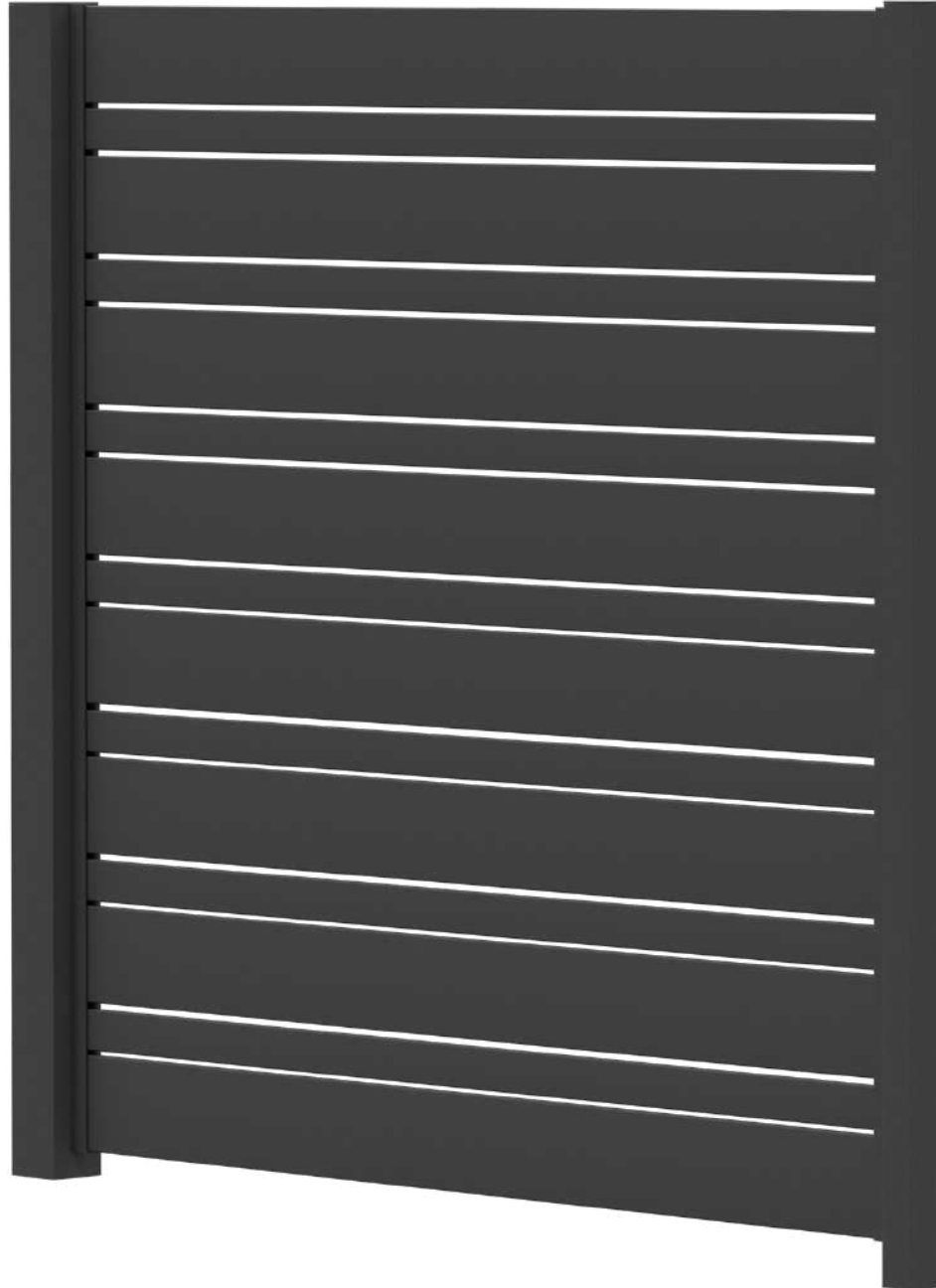

Powder coat colors —

MONUMENT

WOODLAND
GRAY

PEARL
WHITE

TEXTURED
BLACK

Material Specifications

Aluminum 6005/T5 Structural grade alloy

Universal post-2 9/16" x 2 9/16" (8 gauge)

Slat - 2 9/16" x 5/8" (16 gauge)

Slat - 6" x 5/8" (14 gauge)

All Aluminum is manufactured to US and AUS standards including:

- USA
 - ASTM B221 – Aluminum and Aluminum-Alloy Extruded Bars, Rods, Wire, Profiles, and Tubes
 - ASTM B557 – Tension Testing of Aluminum Products
 - ANSI H35.2:2017 - Tolerances aluminum extrusions
- AUS
 - AS/NZS 1866 – Aluminum and aluminium alloys – Extruded rod, bar, solid and hollow shapes
 - AS/NZS 1664 – Aluminium structures
 - AS 2848.1 – Aluminium and aluminium alloys – Compositions and designation

Coating and Finishes:

- AMMA 2604 - Finishing standard Inc
- ASTM B117 – Salt Spray (Corrosion) Testing
- ASTM D3359 – Adhesion of Coatings
- ASTM D1730 – Preparation of Aluminum Surfaces for Paints/Coatings
- ASTM D4214 - Chalking Resistance.

Construction and Building applications.

- AAMA 2604
- ASCE SEI 7-10 - Minimum design loads for buildings and other structures
- AS2159 - Soil properties for footing depths
- AS1530 - Non combustible testing in accordance with ISO 1182:2010
- Australia/NZ – AS/NZS 1530.3 D2525

72" wide x 71" high Quickscreen slat panel 3/8" spacing

- 2 x Blank Post - 2 9/16" x 2 9/16" (incl caps) (95" L)
- OR Blank Post - 4" x 4" (incl caps) (95" L)
- 2 x Side Frame with Friction Insert and Top & Bottom Plates
- 8 x 6"x 5/8" slats (71" L)
- 7 x 2 9/16"x 5/8" slats (71" L)
- 30 x 3/8" snap in spacers

72" wide x 71" high Quickscreen slat panel 1/2" spacing

- 2 x Blank Post - 2 9/16" x 2 9/16" (incl caps) (95" L)
- OR Blank Post - 4" x 4" (incl caps) (95" L)
- 2 x Side Frame with Friction Insert and Top & Bottom Plates
- 8 x 6"x 5/8" slats (71" L)
- 6 x 2 9/16"x 5/8" slats (71" L)
- 28 x 1/2" snap in spacers

72" wide x 71" high Quickscreen slat panel 1" spacing

- 2 x Blank Post - 2 9/16" x 2 9/16" (incl caps) (95" L)
- OR Blank Post - 4" x 4" (incl caps) (95" L)
- 2 x Side Frame with Friction Insert and Top & Bottom Plates
- 7 x 6"x 5/8" slats (71" L)
- 6 x 2 9/16"x 5/8" slats (71" L)
- 26 x 1" snap in spacers

96" wide x 71" high Quickscreen slat panel 3/8" spacing

- 2 x Blank Post - 2 9/16" x 2 9/16" (incl caps) (95" L)
- OR Blank Post - 4" x 4" (incl caps) (95" L)
- 2 x Side Frame with Friction Insert and Top & Bottom Plates
- 8 x 6"x 5/8" slats (95" L)
- 7 x 2 9/16"x 5/8" slats (95" L)
- 30 x 3/8" snap in spacers

96" wide x 71" high Quickscreen slat panel 1/2" spacing

- 2 x Blank Post - 2 9/16" x 2 9/16" (incl caps) (95" L)
- OR Blank Post - 4" x 4" (incl caps) (95" L)
- 2 x Side Frame with Friction Insert and Top & Bottom Plates
- 8 x 6"x 5/8" slats (95" L)
- 6 x 2 9/16"x 5/8" slats (95" L)
- 28 x 1/2" snap in spacers

96" wide x 71" high Quickscreen slat panel 1" spacing

- 2 x Blank Post - 2 9/16" x 2 9/16" (incl caps) (95" L)
- OR Blank Post - 4" x 4" (incl caps) (95" L)
- 2 x Side Frame with Friction Insert and Top & Bottom Plates
- 7 x 6"x 5/8" slats (95" L)
- 6 x 2 9/16"x 5/8" slats (95" L)
- 26 x 1" snap in spacers

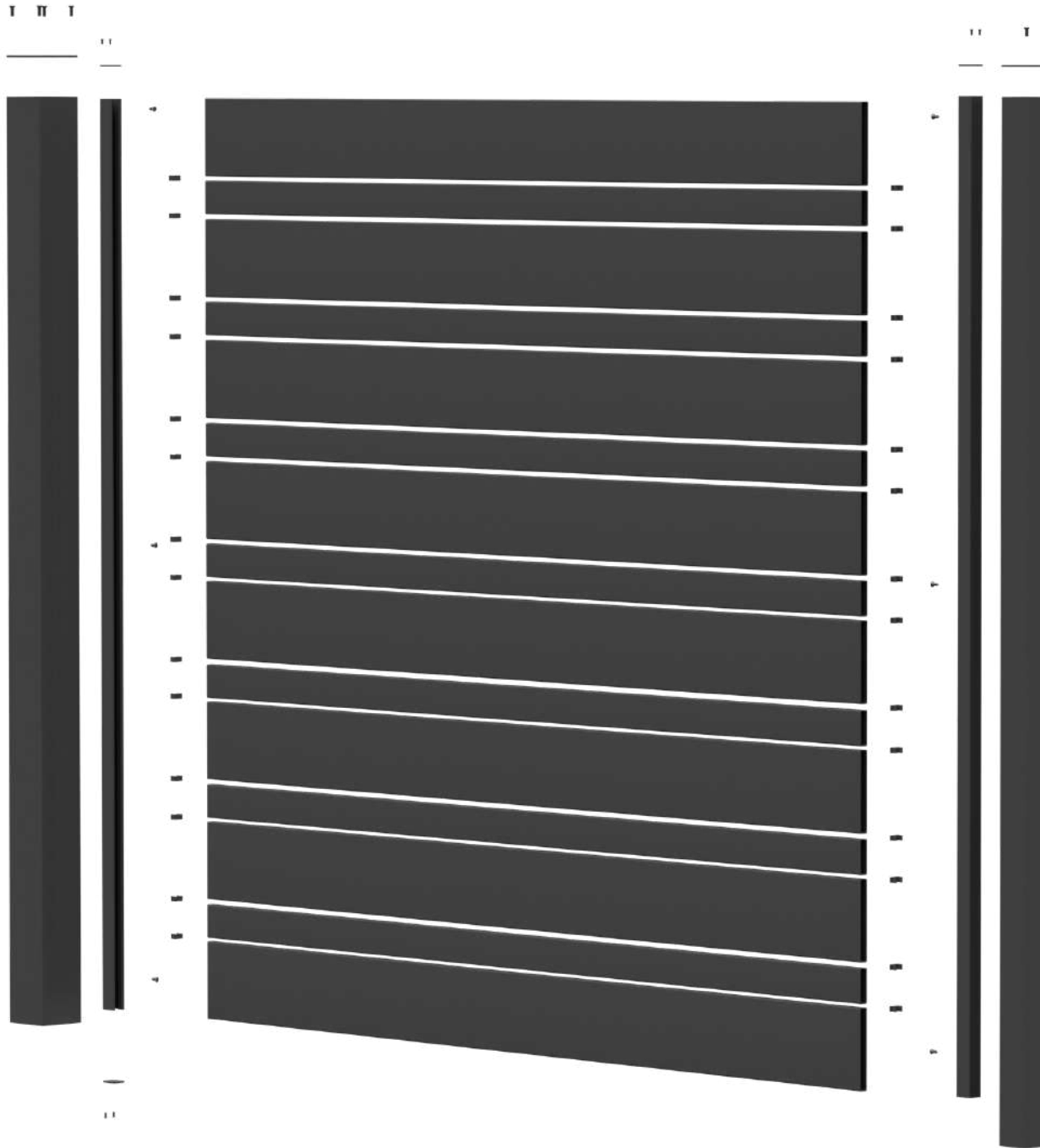

Powder coat colors —



Material Specifications

Aluminum 6005/15 Structural grade alloy

Universal post-2 9/16" x 2 9/16" (8 gauge)

Slot - 2 9/16" x 5/8" (16 gauge)

Slot - 6" x 5/8" (14 gauge)

All Aluminum is manufactured to US and AUS standards including:

USA
ASTM B221 – Aluminum and Aluminum-Alloy Extruded Bars, Rods, Wire, Profiles, and Tubes
ASTM B557 – Tension Testing of Aluminum Products
ANSI H35.2-2017 - Tolerances aluminum extrusions

AUS
AS/NZS 1866 – Aluminium and aluminium alloys – Extruded rod, bar, solid and hollow shapes
AS/NZS 1664 – Aluminium structures
AS 2848.1 – Aluminium and aluminium alloys – Compositions and designation

Coating and Finishes:

AMMA 2604 - Finishing standard Inc
ASTM B 117 – Salt Spray (Corrosion) Testing
ASTM D3359 – Adhesion of Coatings
ASTM D1730 – Preparation of Aluminum Surfaces for Paints/Coatings
ASTM D4214 - Chalking Resistance.

Construction and Building applications.

AAMA 2604
ASCE SEI 7-10 - Minimum design loads for buildings and other structures
AS2159 - Soil properties for footing depths
AS1530 - Non combustible testing in accordance with ISO 1182.2010
Australia/NZ – AS/NZS 1530.3 D2525

Single Gate (42 wide) 3/8" Spacing

- 2 x gate frames Inc screw cover (72" L)
- 1 x Gate frame kit (4 caps and screws)
- SS304 screws HD 12G Qty
- 4x 6" x 5/8" slats (cut into 2) (71" L)
- 4 x 2 9/16" x 5/8" (cut into 2) slats (71" L)
- 30 x 3/8" snap in spacers

Single Gate (42 wide) 1/2" Spacing

- 2 x gate frames Inc screw cover (72" L)
- 1 x Gate frame kit (4 caps and screws)
- SS304 screws HD 12G Qty
- 4x 6" x 5/8" slats (cut into 2) (71" L)
- 3 x 2 9/16" x 5/8" (cut into 2) slats (71" L)
- 28x 1/2" snap in spacers

Single Gate (42 wide) 1" Spacing

- 2 x gate frames Inc screw cover (72" L)
- 1 x Gate frame kit (4 caps and screws)
- SS304 screws HD 12G Qty
- 4x 6" x 5/8" slats (cut into 2) (71" L)
- 3 x 2 9/16" x 5/8" (cut into 2) slats (71" L)
- 26 x 1" snap in spacers

GATE OPTIONS

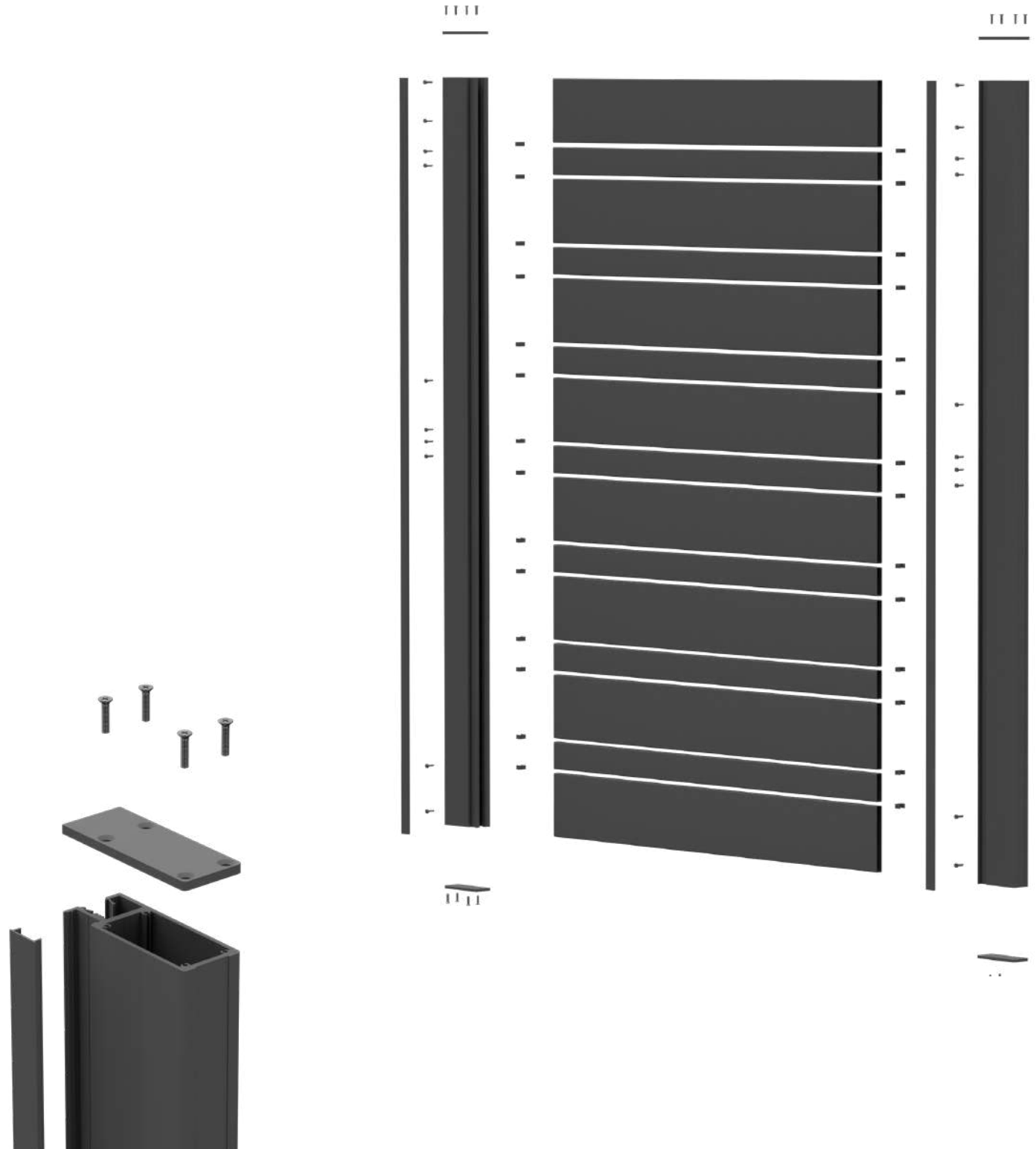

Powder coat colors —

MONUMENT

WOODLAND
GRAY

PEARL
WHITE

TEXTURED
BLACK

Material Specifications

Aluminum 6005/15 Structural grade alloy

Universal post-2 9/16" x 2 9/16" (8 gauge)

Slat - 2 9/16" x 5/8" (16 gauge)

Slat - 6" x 5/8" (14 gauge)

All Aluminum is manufactured to US and AUS standards including:

- USA
 - ASTM B221 – Aluminum and Aluminum-Alloy Extruded Bars, Rods, Wire, Profiles, and Tubes
 - ASTM B557 – Tension Testing of Aluminum Products
 - ANSI H35.2-2017 - Tolerances aluminum extrusions
- AUS
 - AS/NZS 1866 – Aluminium and aluminium alloys – Extruded rod, bar, solid and hollow shapes
 - AS/NZS 1664 – Aluminium structures
 - AS 2848.1 – Aluminium and aluminium alloys – Compositions and designation

Coating and Finishes:

- AMMA 2604 - Finishing standard Inc
- ASTM B 117 – Salt Spray (Corrosion) Testing
- ASTM D3359 – Adhesion of Coatings
- ASTM D1730 – Preparation of Aluminum Surfaces for Paints/Coatings
- ASTM D4214 - Chalking Resistance.

Construction and Building applications.

- AAMA 2604
- ASCE SEI 7-10 - Minimum design loads for buildings and other structures
- AS2159 - Soil properties for footing depths
- AS1530 - Non combustible testing in accordance with ISO 1182.2010
- Australia/NZ – AS/NZS 1530.3 D2525

Double gate (192" wide)

- 4 x gate frames Inc screw cover (72" L)
- 2 x Gate frame kit (4 caps and screws)
- SS304 screws HD 12G Qty
- 16 x 6" x 5/8" slats (95" L)
- 14 x 2 9/16" x 5/8" slats (95" L)
- 60 x 3/8" snap in spacers

Double gate (192" wide)

- 4 x gate frames Inc screw cover (72" L)
- 2 x Gate frame kit (4 caps and screws)
- SS304 screws HD 12G Qty
- 16 x 6" x 5/8" slats (95" L)
- 12 x 2 9/16" x 5/8" slats (95" L)
- 56 x 1/2" snap in spacers

Double gate (192" wide)

- 4 x gate frames Inc screw cover (72" L)
- 2 x Gate frame kit (4 caps and screws)
- SS304 screws HD 12G Qty
- 14 x 6" x 5/8" slats (95" L)
- 12 x 2 9/16" x 5/8" slats (95" L)
- 52 x 1" snap in spacers

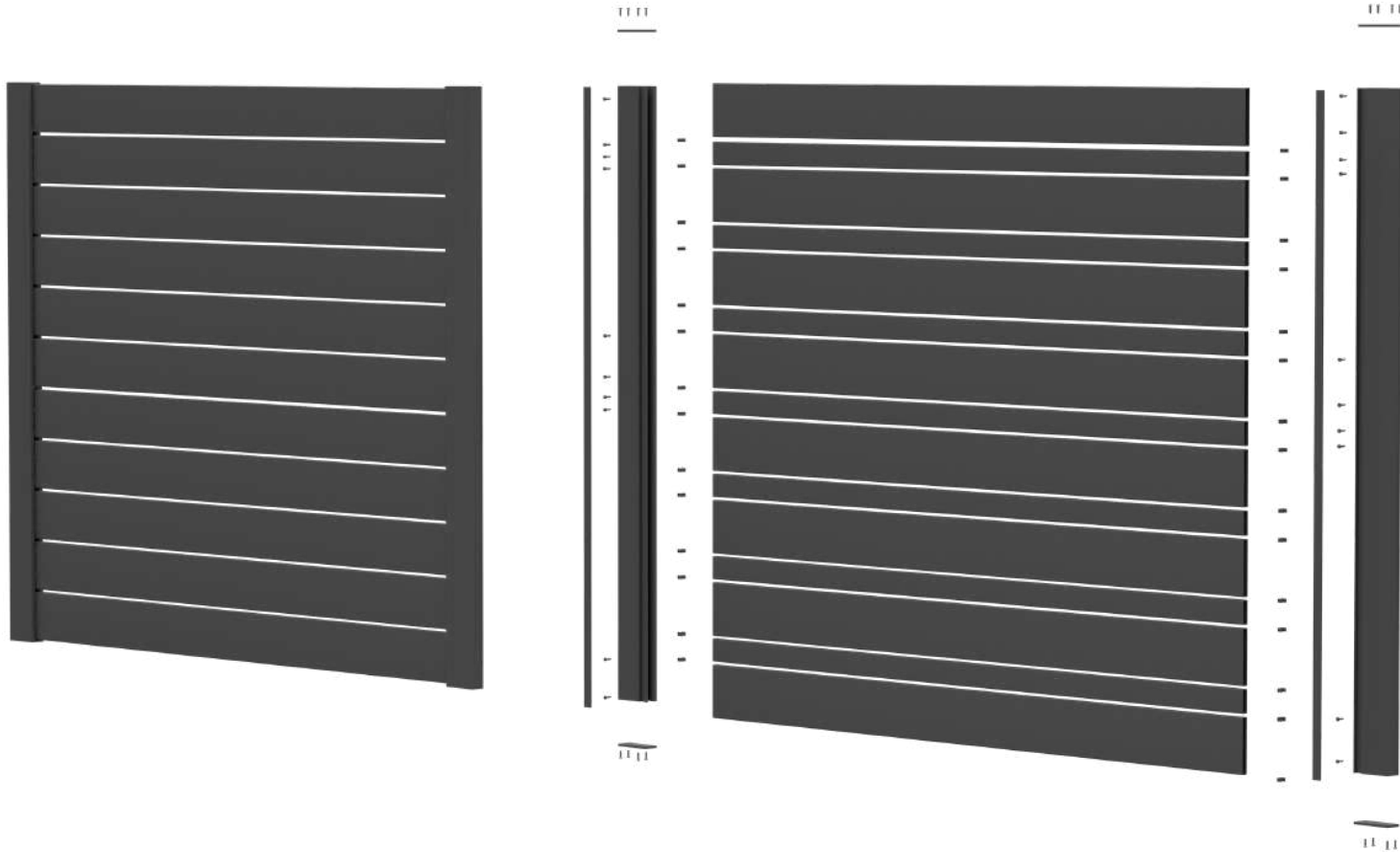

Powder coat colors —

